

MotorGuide® REPAIR PARTS

Model:
ST2000VE

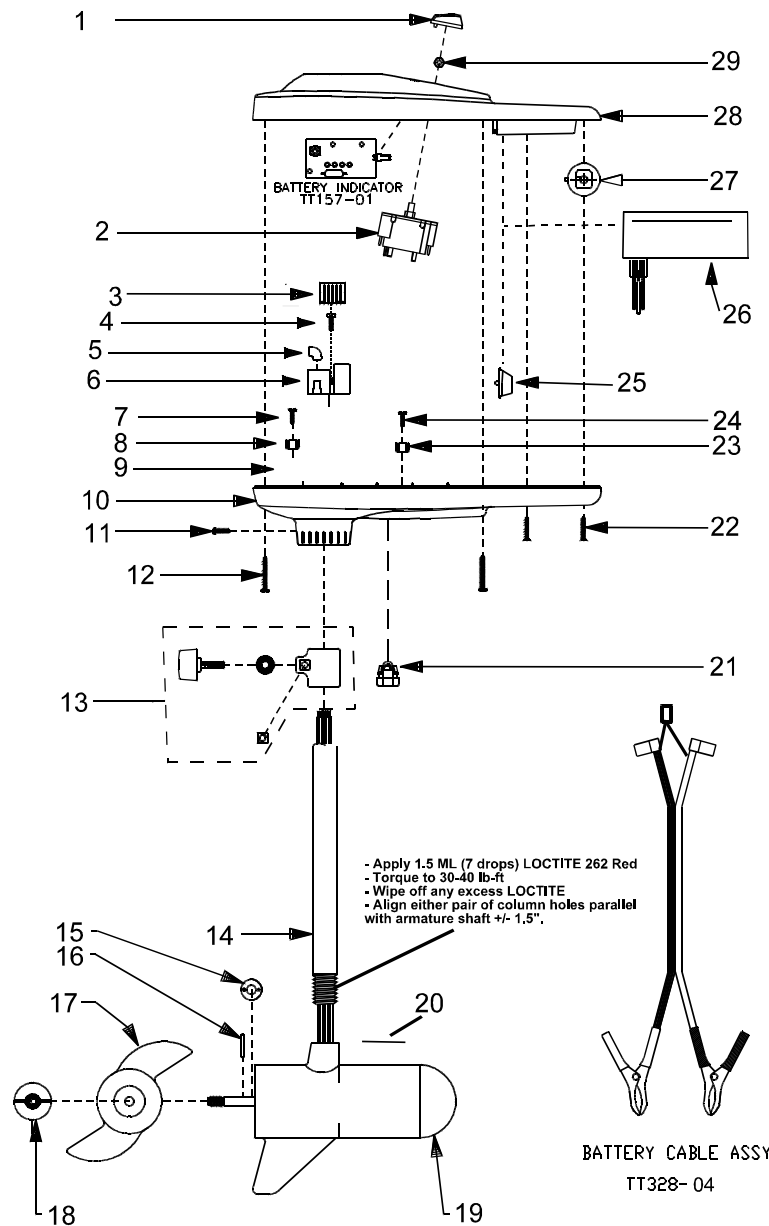

SPECIFICATIONS:

Year	1994
Thrust	40LBS
Volts	12VDC
Amp Draw	0 to 48amps
Mount	03
Speeds	Variable

PARTS ORDERING & TECH ASSISTANCE

MotorGuide Consumer Relations
Phone 918-831-6989
Fax 800-982-8093

Send Returned Goods to:
MotorGuide
605 Hwy 12 West
Starkville, MS 39760

Returned Goods must be accompanied with a Returned Goods Authorization. Contact MotorGuide Consumer Relations to obtain RGA.

KEY	DESCRIPTION	PART #	KEY	DESCRIPTION	PART #
1	KNOB	TT082-03	27	ON/OFF HANDLE ASSY	TT372-01
2	ROTARY SWITCH	KT150-02	28	T/H COVER	KT053-11
3	AMP CONNECTOR	AP029-01	29	NUT	AT098-01
4	SCREW	AF141-01			
5	INSULATOR	AT080-01			
6	DA BOARD	JF157-03			
7	#10x 1/2" SCREW	GR133-01			
8	TERMINAL	FT160-03			
9	ONSERT PAL NUT	TT098-03			
10	T/H BASE	TF004-04			
11	8 X 1-3/8 SCREW	AR133-01			
12	8 X 1-3/8 SCREW	AR133-01			
13	DEPTH COLLAR ASY	AR158-01			
14	30" COLUMN	TT049-01			
15	MONOFILAMENT WASHER	AR175-01			
16	PROP DRIVE PIN	BR102-01			
17	PROP	AF124-10			
18	PROP NUT	AR099-01			
19	MOTOR	GF397-01			
20	MARINE LOWER UNIT DECAL	ET060-04			
21	GROMMET	GR019-03			
22	#4x 1" SCREW	TT141-02			
23	TERMINAL	FT160-03			
24	#10x 1/2" SCREW	GR133-01			
25	POT ACTUATOR	TT3001-02			
26	SLIDE POTENTIOMETER	TT168-03			

LOWER UNIT BREAKDOWN

Model:
ST2000VE

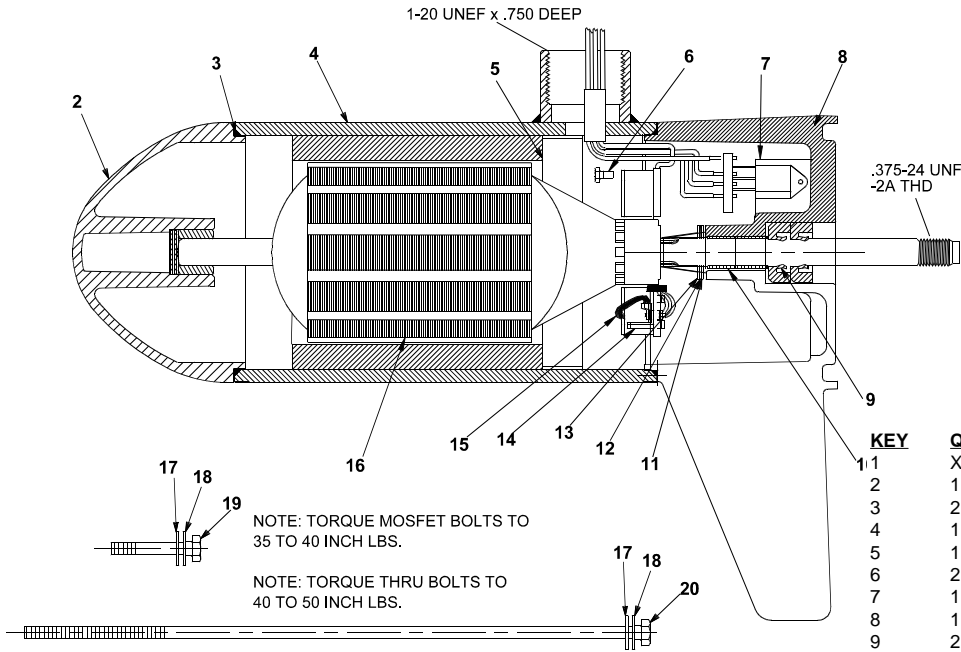

NOTE: TORQUE MOSFET BOLTS TO 35 TO 40 INCH LBS.

NOTE: TORQUE THRU BOLTS TO 40 TO 50 INCH LBS.

DIRECTION OF ROTATION IS COUNTER CLOCKWISE WHEN VIEWED FROM PROPELLER END WITH RED POSITIVE & BLACK NEGATIVE.

KEY	QTY	DESCRIPTION	PART NO.
1	X	MOTOR	GF397-01
2	1	NOSE CAP	JF3212-01
3	2	O RING SEAL	MR217-01
4	1	HOUSING ASY	GF3210-01
5	1	RETAINER	JF233-01
6	2	BRUSH CARD SCREW	MR228-01
7	1	DURA AMP MODULE	JF096-07
8	1	COMM CAP	JF3205-04
9	2	SHAFT SEAL	MR223-01
10	1	BEARING	MR206-01
11	1	NYLATRON WASHER	MR226-01
12	1	WASHER	MR227-01
13	1	E RING	MR219-02
14	2	BRUSH SPRINGS	MR214-02
15	1	BRUSH ASY LESS SPRING	GF3201-01
16	1	ARMATURE 3.5"	GF3207-01
17	4	STATIC SEAL	MR222-01
18	4	THRU BOLT WASHER	MR216-01
19	2	DURA AMP SCREW	MR229-04
20	2	THRU BOLT	MR218-04

WIRING

